

5 PIECES HOIST SYSTEM

The 5 pieces Hoist System was conceived to be use in conjunction with Davit Arm # IN-2002 and our Mast #IN-2003. It will facilitate your access to underground chamber or any other confined spaces. Once again Innova is offering you the most universal system on the market. Always using same Mast IN-2003 and same Davit Arm IN-2002, you will find your work much more pleasant. It's gives you a maximum capacity of 360lbs (safety factor 10:1). It also provides you 5000lbs anchor point following safety regulations. Meets or exceeds (CSA-OSHA-CSST) regulations.

C
O
N
F
I
N
E
D

S
P
A
C
E

R
E
S
C
U
E

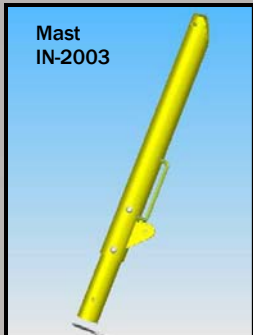
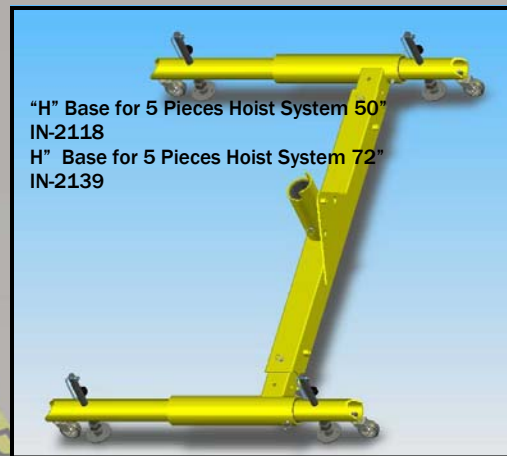
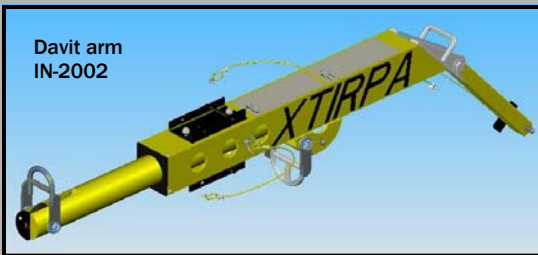

CARACTERISTICS

Davit arm	IN-2002
Weight	23lbs
Length open	80 inches
Length close	52 inches

Mast	IN-2003
Weight	22lbs
Height	55po

" H " Base for 5 pieces Hoist System 50"	IN-2118
Weight	85lbs
' H " Base for 5 pieces Hoist System 72"	IN-2139
Weight	93lbs